

APRO

Windows Automation

THE NEW LINE OF  
**INTELLIGENT SYSTEMS**  
FOR THE **WINDOWS**  
**OF THE FUTURE**

---

*LA NUOVA LINEA  
DI **SISTEMI INTELLIGENTI**  
PER LE **FINESTRE**  
**DEL FUTURO***

[myapro.it](http://myapro.it)







APRO  
Windows Automation



SECURITY  
SYSTEM



SMART  
CONTROL



AUTOMATIC  
ROUTINE

## IT

APRO nasce da un progetto di ricerca industriale con l'obiettivo di sviluppare una gamma di accessori in grado di trasformare un qualsiasi serramento in un elemento di home automation integrato.

APRO rappresenta quindi la linea di sistemi intelligenti per le finestre del futuro che permette di:

- Gestire il controllo degli accessi
- Garantire elevati standard di sicurezza
- Assicurare il massimo comfort abitativo

## FR

APRO est né d'un projet de recherche industrielle dans le but de développer une gamme d'accessoires capables de transformer n'importe quelle fenêtre en un élément intégré de domotique.

APRO représente donc la ligne de systèmes intelligents pour les fenêtres du futur qui vous permet de:

- Gérer le contrôle d'accès
- Garantir des normes de sécurité élevées
- Assurer un confort de vie maximal

## EN

APRO was born from an industrial research project with the aim of developing a range of accessories capable of transforming any window into an integrated home automation element.

APRO therefore represents the line of intelligent systems for the windows of the future that allows you to:

- Manage access control
- Guarantee high safety standards
- Ensure maximum living comfort

## ES

APRO nace de un proyecto de investigación industrial con el objetivo de desarrollar una gama de accesorios capaces de transformar cualquier ventana en un elemento domótico integrado.

APRO por lo tanto representa la línea de sistemas inteligentes para las ventanas del futuro que le permite:

- Administrar el control de acceso
- Garantizar altos estándares de seguridad
- Garantice el máximo confort de vida

# Attuatori a catena/Chain Actuator

## IT

Gli attuatori APRO sono disponibili nelle versioni ad incasso nel profilo (invisibili) o ad applicazione esterna e possono essere integrati con gateway e app oltre ad essere installati in combinazione con altri attuatori o con i sistemi di chiusura APRO.

## EN

The APRO actuators are available in the versions concealed in the profile (invisible) or for external application and can be integrated with gateways and apps as well as being installed in combination with other actuators or with APRO locking systems.

## FR

Les actionneurs APRO sont disponibles dans les versions encastrées dans le profil (invisibles) ou pour application externe et peuvent être intégrés avec des passerelles et des applications ainsi qu'être installés en combinaison avec d'autres actionneurs ou avec des systèmes de verrouillage APRO.

## ES

Los actuadores APRO están disponibles en las versiones empotradas en el perfil (invisibles) o para aplicación externa y pueden integrarse con pasarelas y aplicaciones, así como instalarse en combinación con otros actuadores o con sistemas de cierre APRO.

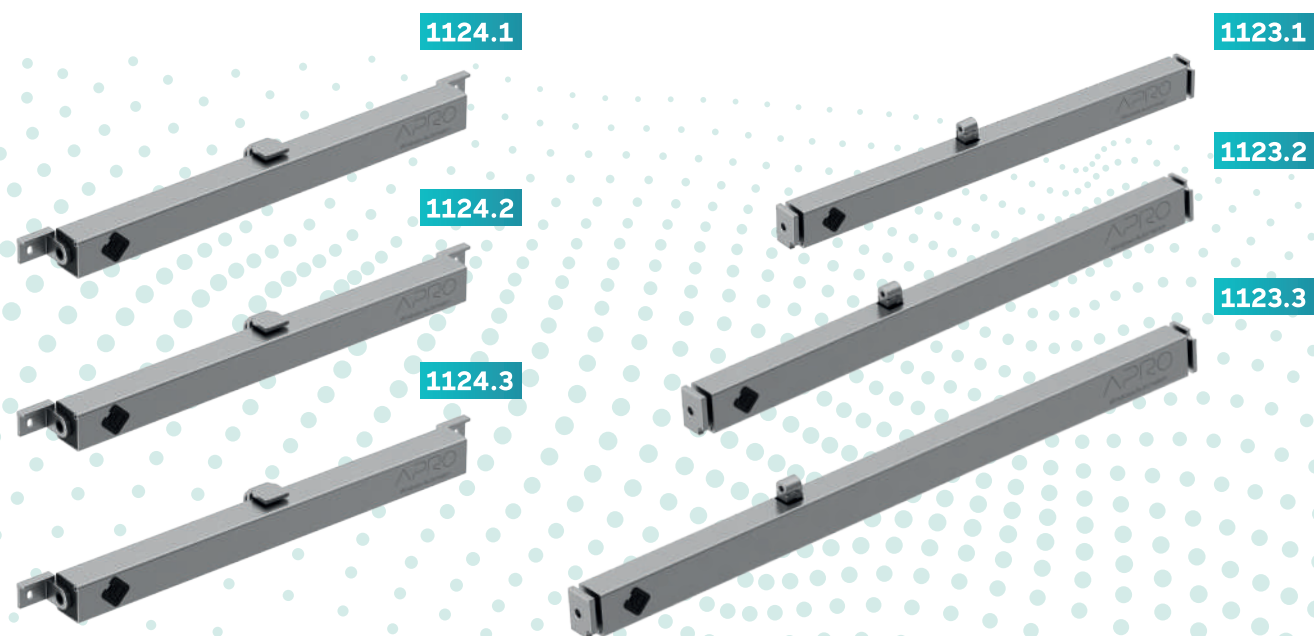

ART.	MODELLO MODEL	APPLICAZIONE APPLICATION	SPINTA PULL	TENSIONE VOLTAGE	CORSA STROKE mm
1124.1	APRO-CE250N24V210CE	<b>Attuatore a catena ad incasso-CE</b> Concealed chain Actuator Actionneur à chaîne à encastrement Actuador de cadena embutido	250N	24V	100 - 160 - 210
1124.2	APRO-CE250N24V210R	<b>Attuatore a catena ad incasso-R</b> Concealed chain Actuator Actionneur à chaîne à encastrement Actuador de cadena embutido	250N	24V	100 - 160 - 210
1124.3	APRO-CE250N24V210W	<b>Attuatore a catena ad incasso-wood</b> Concealed chain Actuator Actionneur à chaîne à encastrement Actuador de cadena embutido	250N	24V	100 - 160 - 210
1123.1	APRO-CE350N24V300	<b>Attuatore a catena</b> Chain Actuator Actionneur à chaîne Actuador de cadena	350N	24V	150 - 200 - 300
1123.2	APRO-CE350N24V400	<b>Attuatore a catena</b> Chain Actuator Actionneur à chaîne Actuador de cadena	350N	24V	300 - 350 - 400
1123.3	APRO-CE350N24V600	<b>Attuatore a catena</b> Chain Actuator Actionneur à chaîne Actuador de cadena	350N	24V	500 - 600

# Sistemi di chiusura/Locking Systems

## IT

I sistemi di chiusura APRO sono disponibili in versione elettro-serratura ad incasso o chiusura frangisole, possono essere integrati con gateway e app oltre ad essere installati in combinazione con altri sistemi della linea APRO.

## EN

The APRO locking systems are available in the built-in electro-lock or sunshade locking version, they can be integrated with gateways and apps as well as being installed in combination with other systems of the APRO line.

## FR

Les systèmes de verrouillage APRO sont disponibles dans la version à verrouillage électrique ou pare-soleil intégré, ils peuvent être intégrés avec des passerelles et des applications ainsi qu'être installés en combinaison avec d'autres systèmes de la ligne APRO.

## ES

Los sistemas de cierre APRO están disponibles en la versión con cierre eléctrico o parasol integrado, pueden integrarse con pasarelas y aplicaciones, así como instalarse en combinación con otros sistemas de la línea APRO.

1125.1



1125.12

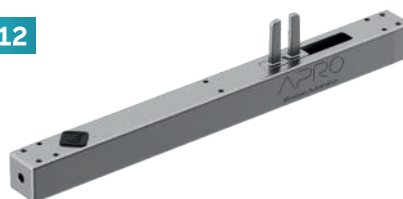

1125.11

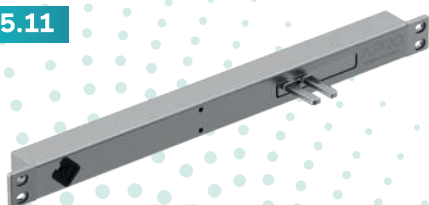

1125.13



ART.	MODELLO MODEL	APPLICAZIONE APPLICATION	SPINTA PULL	TENSIONE VOLTAGE	CORSA STROKE mm
1125.1	APRO-LI600N24V34CE	<b>Elettro-serratura da incasso-CE</b> Electro Lock concealed Serrure électromécanique à encastrement Cerradura electromecánica embutida	600N	24V	0 - 17 - 34
1125.2	APRO-LI600N24V34R	<b>Elettro-serratura da incasso-R</b> Electro Lock concealed Serrure électromécanique à encastrement Cerradura electromecánica embutida	600N	24V	0 - 40
1125.11	APRO-LE600N24V34	<b>Elettro-serratura da incasso</b> Electro Lock concealed Serrure électromécanique à encastrement Cerradura electromecánica embutida	600N	24V	0 - 34
1125.12	APRO-LS600N24V34	<b>Elettro-serratura</b> Electro Lock Serrure électromécanique Cerradura electromecánica	600N	24V	0 - 34
1125.13	APRO-LS600N24V40	<b>Elettro-serratura</b> Electro Lock Serrure électromécanique Cerradura electromecánica	600N	24V	0 - 40



## Sistemi di controllo/Control Systems



ART.	MODELLO MODEL	APPLICAZIONE APPLICATION
1126	APRO-NET	<p><b>IT: Gateway per controllo da remoto   uso residenziale   fino a 12 dispositivi</b>            EN: Gateway for remote control   residential use   manages 12 devices            FR: Gateway   usage résidentiel   gère jusqu'à 12 appareils            ES: Gateway   uso residencial   gestiona hasta 12 dispositivos</p>
1126.5	APRO-NET-DIN	<p><b>IT: Gateway per controllo da remoto   uso residenziale   fino a 12 dispositivi   barra DIN</b>            EN: Gateway for remote control   residential use   manages 12 devices   DIN rail            FR: Gateway   usage résidentiel   gère jusqu'à 12 appareils   Rail DIN            ES: Gateway   uso residencial   gestiona hasta 12 dispositivos   Carrill DIN</p>
1126.10	APRO-NET-PRO	<p><b>IT: Gateway professionale ModBus per integrazione con sistemi di BMS   barra DIN</b>            EN: Professional gateway ModBus for integration with BMS systems   Din rail            FR: Gateway professionnelle ModBus pour intégration avec des systèmes BMS   Rail Din            ES: Gateway profesional ModBus para integración con sistema BMS   Carrill DIN</p>

### > APRO APP

**IT: Applicazione dedicata per Smartphone e Tablet per gestione attuatori da remoto con Gateway 1126 - 1126.5**

EN: Dedicated application for Smartphone and Tablet for remote actuator management with 1126 - 1126.5 gateways

FR: Application dédiée pour Smartphone et Tablette pour la gestion à distance des actionneurs avec Gateway 1126 - 1126.5

ES: Aplicación dedicada para Smartphone y Tablet para la gestión remota de actuadores con Gateway 1126 - 1126.5

## Accessori/Accessories

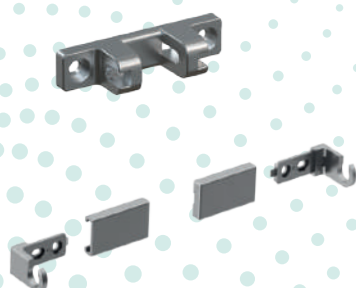

1123.16

**IT: Kit staffe vasistas/sporgere**

EN: Bracket kit bottom/top hung

FR: Kit étriers soufflet/projectant

ES: Kit de bridas basculante/rojectante

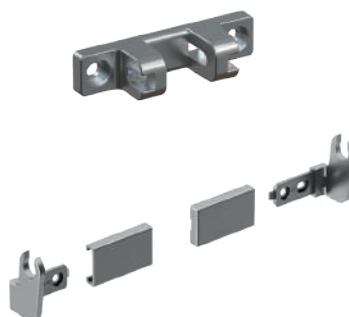

1123.17

**IT: Kit staffe sporgere**

EN: Bracket kit top hung

FR: Kit étriers projectant

ES: Kit de bridas projectante

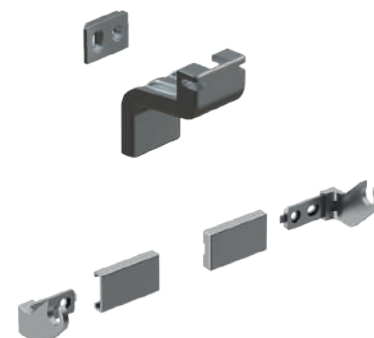

1123.18

**IT: Kit staffe vasistas**

EN: Bracket kit bottom

FR: Kit étriers soufflet

ES: kit de bridas basculante



# APRO

Windows Automation



myapro.it



**MASTER ITALY S.R.L.**

S.P. 37 Conversano - Castiglione km 0.570  
70014 Conversano (Ba) Italy

**Customer Service APRO**

  +39 366 667 6122  
support@myapro.it

